

NEW Processing Unit 40D12

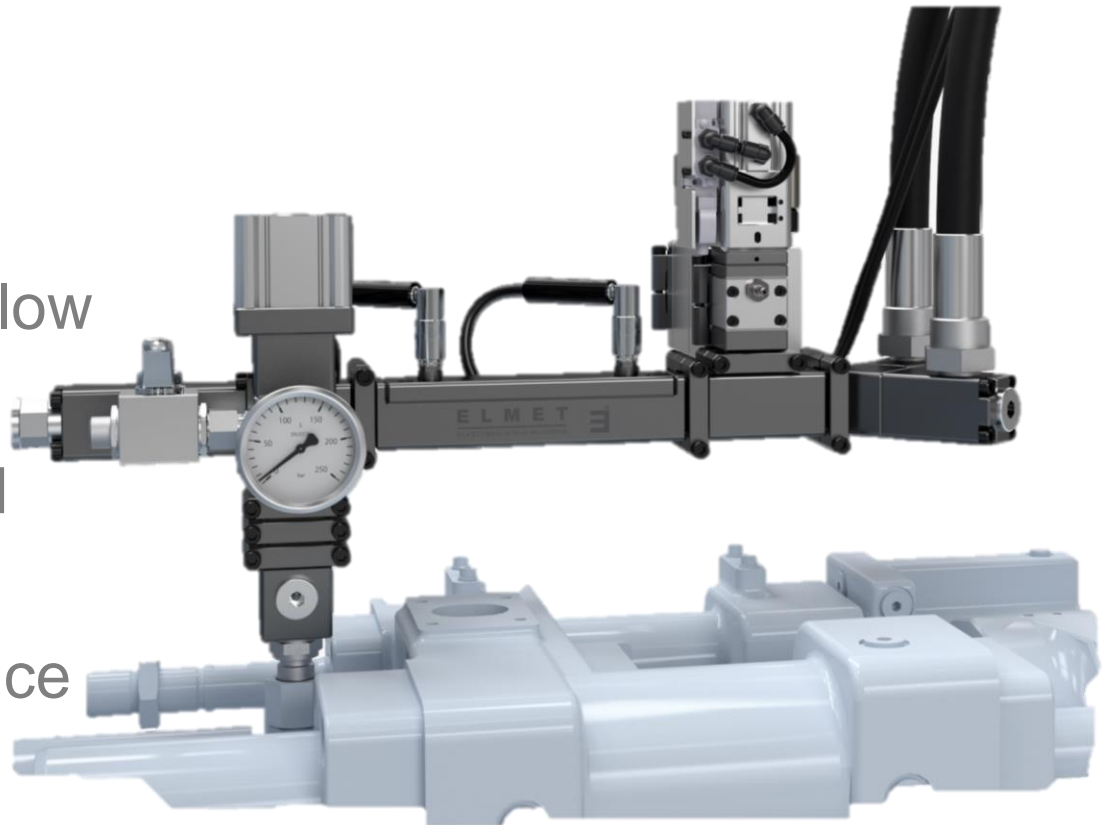

NEW Processing Unit 40D12

- Complete new design
- Flexible Setup
- Optimized material flow
- 50% weight reduced
- 30% less maintenance and cleaning



New designed material channels

- Consistent material channel diameter
- Quick connection for easy handling

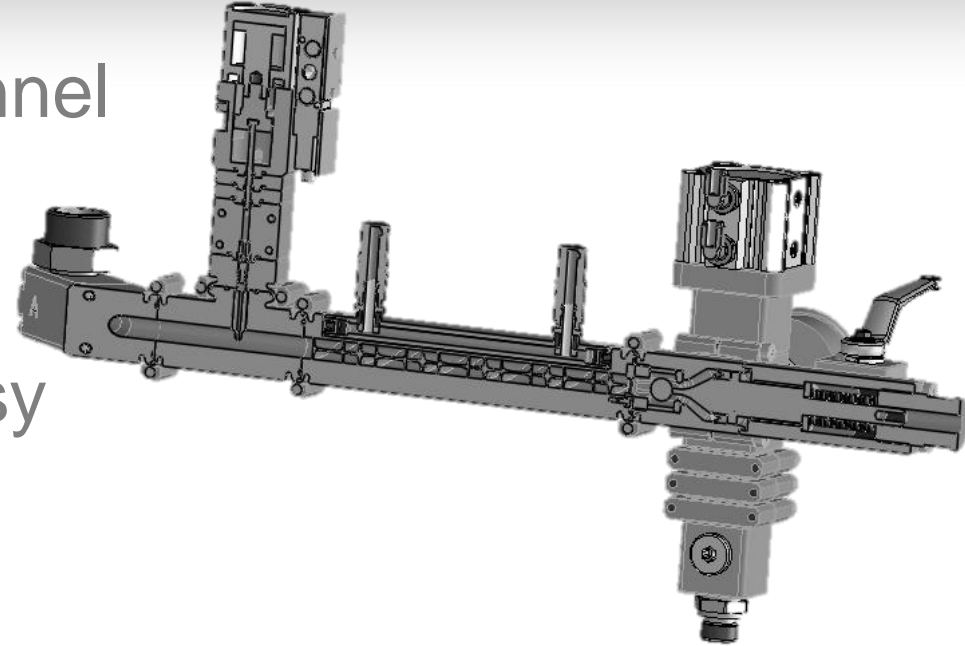
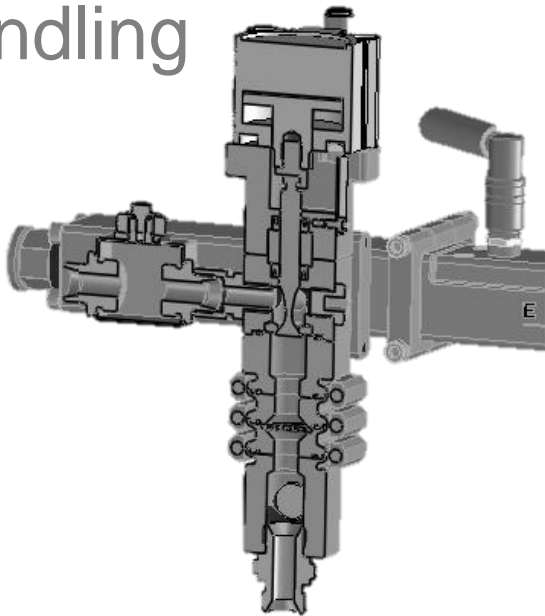

- No dead angle which guarantees no cured material inside



Weight reduction

- All components out of anodized aluminum
=> Medical industry
- Weight reduction from 25.5kg to 11.2kg
- 14.3Kg

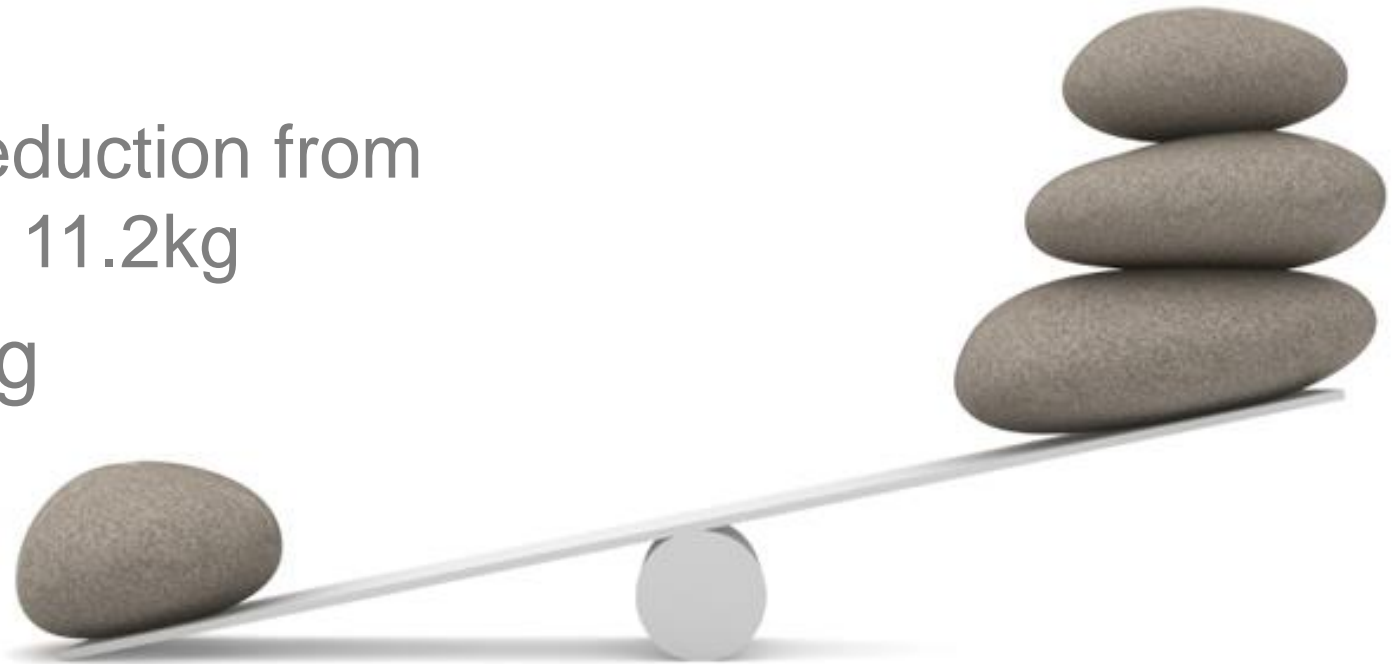



Reinigungszeiten reduziert

- Fast maintenance through new clamping system – quick connection
- Modular system – Set up according to customers needs
- Mixing block can be completely disassembled – easy cleaning

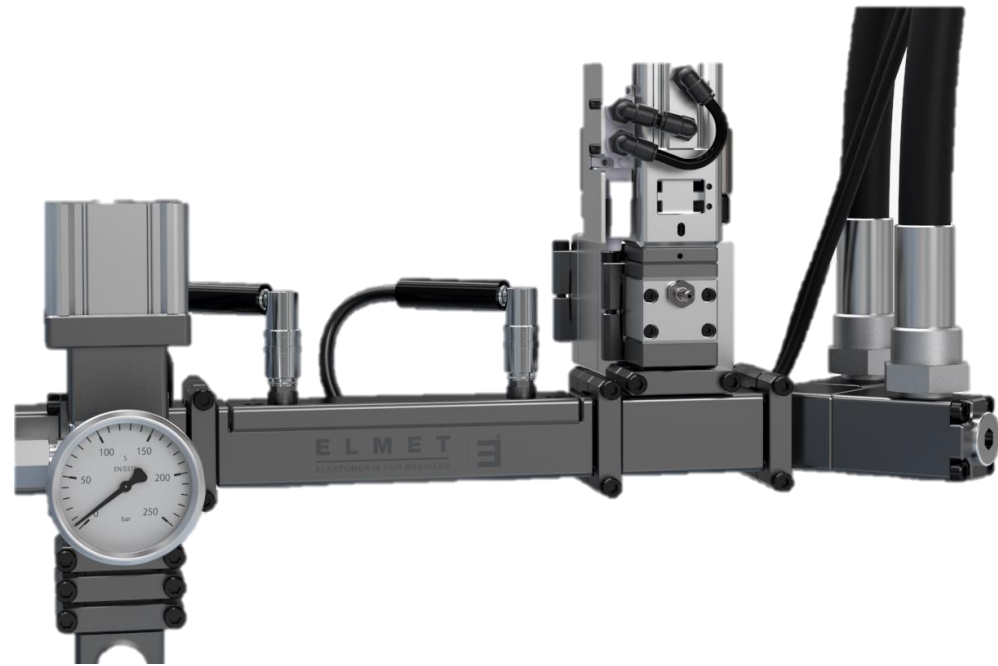



What's new?

- Shut-off valve closes against the flow direction of the material which assist the non return valve at closing
- Cooling jacket integrated at static mixer
- Material pressure limiter adjusted by a 24 open end wrench
- No sharp edges inside => radius
- Quick connections

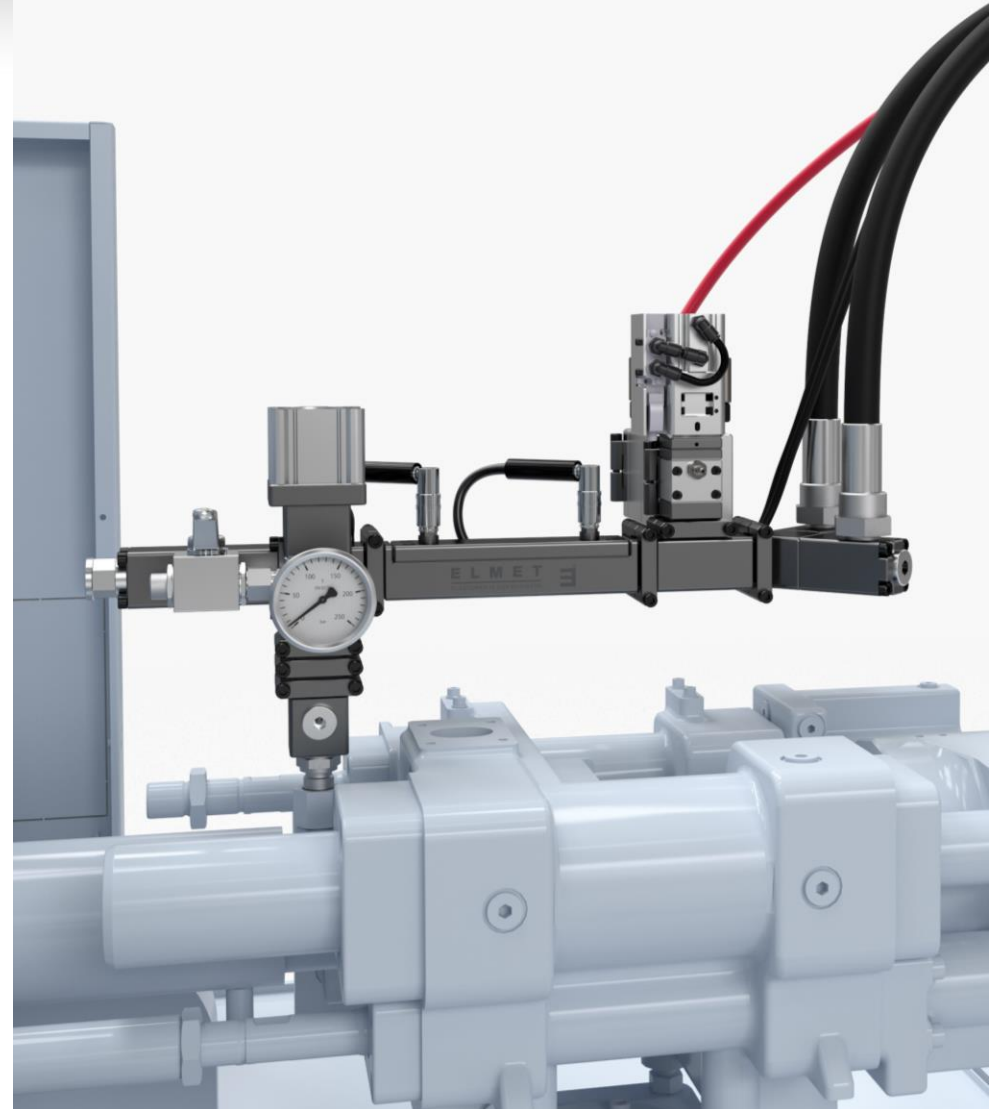

Herzlichen Dank für die Aufmerksamkeit



Oftring, **AUSTRIA**

**ELMET Elastomere Produktions-
und Dienstleistungs GmbH**



Lansing, **USA**

ELMET North America Inc.

www.elmet.com